

LKE Group
Excellence in material handling

How we work

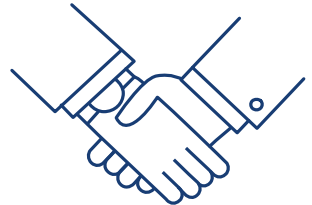
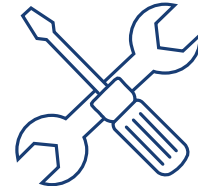
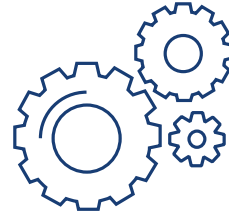
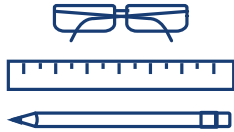
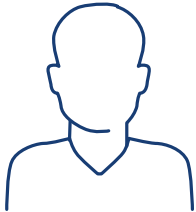

CONSULTING

- Understand needs
- Define requirements
- Develop the solution

DEVELOPMENT

- Expertise in product design
- Specialized in industrial applications

PROTOTYPE

- Idea
- Testing
- Iteration

PRODUCTION

- Large and small quantities
- Short lead times
- High industrial standards

SERVICE

- Maintain operational safety
- Support continuous improvement
- Ensure ergonomic solutions

VALUE

- High investment reliability
- Sustainable quality
- Longevity
- Efficiency

Popular challenges we support

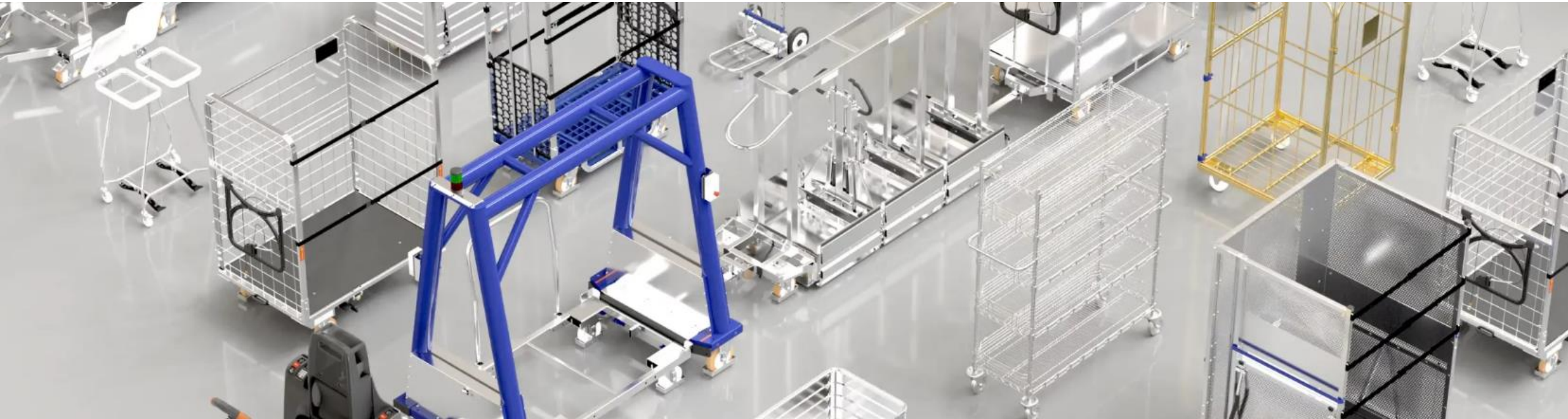

- Improving safety with ergonomic presentation.
- Bespoke handling product required for most effective handling operation.
- The load is damaged or dropped with old trolleys.
- Aim to remove Fork lifts from the facility
- Yearly replacements required due to poor quality old kit
- To improve material flow and implement a train system

Overview



Key Points

- We specialize in trolley solutions - towable, AGV/AMR compatible and manually operated.
- Most of our products are linkable with one another to achieve multi-drop deliveries.
- We offer many industry standard sized products, along with bespoke designs too, to achieve the most effective solution.
- All products are UKCA/CE marked & approved



Products & Uses

Platform Trolleys



Type-X Platform Trolley



Highlights

- Available in two standard sizes (Euro&Industrial)
- Simple hook up and go design
- Excellent direction stability and tracking
- Standard SWL 1000kg
- Type-X for fixed size achievability
- Accessible for FLT to land pallets onto
- Stackable to save space when not in use
- UKCA Certified

Resin Based Platform Trolley



Highlights

- Available in two standard sizes (Euro&Industrial)
- Simple hook up and go design
- Excellent direction stability and tracking
- Standard SWL 1000kg
- Resin base to allow for multiple sized loads
- If contents of pallet is wet, the resin base helps to prevent internal floors from drips/water.
- Accessible for FLT to land pallets onto
- Stackable to save space when not in use
- UKCA Certified

Mesh Based Platform Trolley



Highlights

- Available in two standard sizes (Euro&Industrial)
- Simple hook up and go design
- Excellent direction stability and tracking
- Standard SWL 1000kg
- Steel mesh base to allow for multiple sized loads
- Accessible for FLT to land pallets onto
- Stackable to save space when not in use
- UKCA Certified

Shelved Trolleys



SLC 600



SLC 600 Shelved Trolley

- SLC600 – 12 x 600x400 KLT boxes
- SWL 500kg
- 100kg per shelf – 300kg on the base
- Double sided loaded & unloading
- Forklift friendly with fork pockets
- Ergonomic handle and brake to assist stopping
- Central footbrake for easy parking in location
- Towable with our other products too
- Customizable
- UKCA Certified

SLC 800



SLC 800 Shelved Trolley

- SLC800 – 16 x 600x400 KLT boxes
- SWL 500kg
- 100kg per shelf – 150kg on the base
- Double sided loaded & unloading
- Forklift friendly with fork pockets
- Ergonomic handle and brake to assist stopping
- Central footbrake for easy parking in location
- Towable with our other products too
- Customizable
- UKCA Certified

SLC 600 - Angled



SLC 600 Angled Shelf Trolley

- SLC600 – 9 x 600x400 KLT boxes
- 100kg per shelf
- Forklift friendly with fork pockets
- Ergonomic handle and brake to assist stopping
- Central footbrake for easy parking in location
- Towable with our other products too
- Customizable
- UKCA Certified

Further spec opportunities



Further specifications

- Weatherproofed
- Caged
- No shelves
- Foldable
- Telescopic shelves
- Custom sizing
- Apex shelves
- UKCA Certified

Industrial Solutions



Distribution and warehousing



lattice box trolley
Mesh container Premium XL
Standard

lattice box trolley
Mesh container Classic X
Standard

lattice box trolley
Mesh container Uniflex "X"
Standard

lattice box trolley
Mesh container Junior X
Standard

shelf trolley
Ecoflex 600 E1 OKD

shelf trolley
Ecoflex 600 E2 OKD

shelf trolley
Ecoflex 600 E1 OKD with base
shelf support

shelf trolley
Ecoflex 600 E3 OKD



Mother Daughter / Roll-on, Roll-off solutions

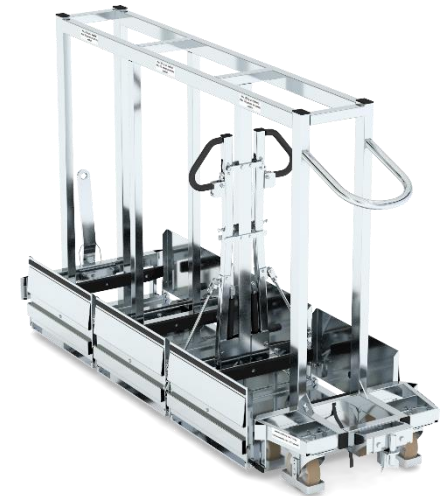
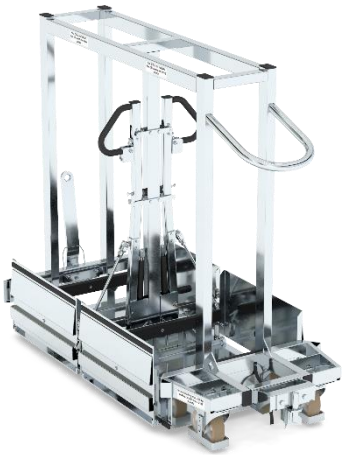

'Mother Daughter' Systems



Cargo Liner

- Roll on/roll off
- No unhooking or disconnecting from the train
- Can work with existing dollies
- Move multiple dollies/bins in one journey
- Custom sizing available
- UKCA Certified

AGV & AMR Compatible products

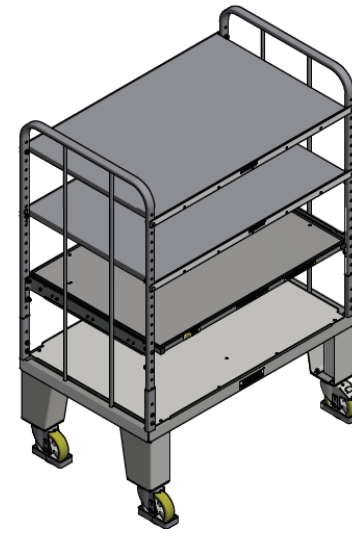

Automation Compatible



Product information

- We have industry standard sized products available as well as the capacity to manufacture bespoke load carriers.
- Dependant on the make/model of robot, we will ensure that the appropriate compatible design is achieved for optimal performance.
- Some of the brands we have worked with so far: ABB, Omron, MIR, Jungheinrich

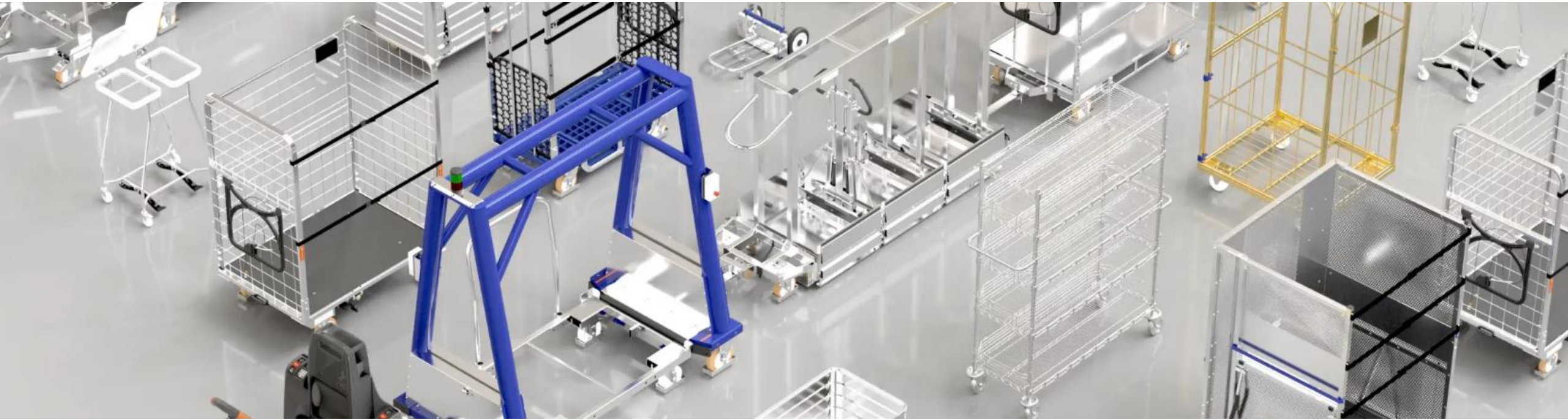

Bespoke designs & capacities

Bespoke design trolleys



Capacities

- Raised bases
- Angled bases
- Low load & ramps
- Custom dimensions
- Scissor lifting
- Over-sized heavy weight
- Weatherproofed
- Specific load with CAD collaboration

Stillage & Container Design

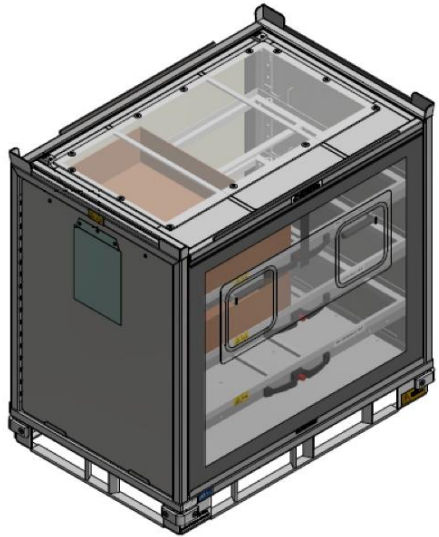

It's not always on wheels..

- Can be landed onto a platform trolley
- Completely bespoke to customer needs
- Weatherproofed
- Stackable
- Good for lineside part presentation
- Good for kit picking
- The right solution for the job
- Forkliftable

Outdoor solutions



Design capabilities

- Can achieve increased ground clearance to help tackle terrain
- Choice of different wheels/castors including Pneumatic for poor ground conditions
- Weather proofing
- Can be made liftable by FLT
- Can be spec'd to stack to save space
- Towable with a range of different Tug devices
- UKCA Certified

Electrically assisted



Available specs

- Towable versions available
- Custom sizing
- Move upto 2000kg easily
- Simple battery operated mechanism
- Linkable with other LKE kit
- Blickle Ergomove system
- Very easy to use!

Brands we work with already!



ASTON MARTIN

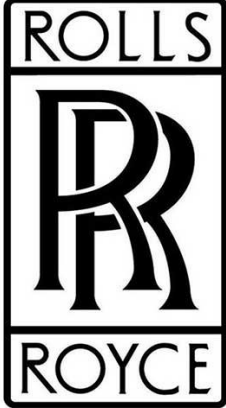

Traceability and Compliance



Weserstraße 2 - D-45768 Marl - Germany Info@LKE-Group.com Tel. +49 (0) 2365/9100 0 www.LKE-Group.com Fax +49 (0) 2365/910010			LKE
Baujahr	Seriennummer	CE UK CA	
Artikel-Nr. : Bezeichnung:		max. Zuladung: max. Geschwindigkeit: max. Zuggewicht:	

Product information

- Fully tested for UKCA & CE Certification
- Product ID labels with serial number and article numbers allowing traceability on all equipment
- Operational handbook

Photo album

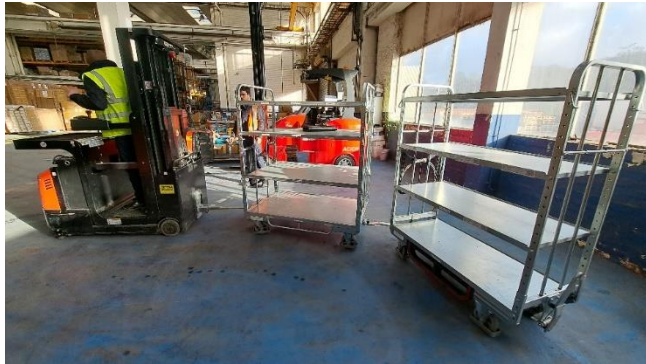



For enquiries please get in touch.

William King

Wking@LKE-Group.com
Phone: +44 7999 028 517

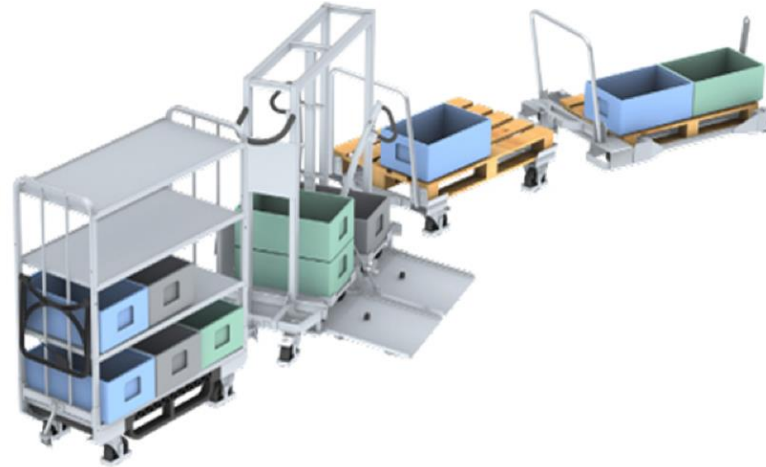

**For enquiries and more
information, please get in
touch.**

William King

LKE UK

Wking@LKE-Group.com

Phone: +44 7999 028 517